

DCB-MMB2-RD78G-2G-35



Dual Counterbalance Manifolds

DESCRIPTION

Dual counterbalance manifolds

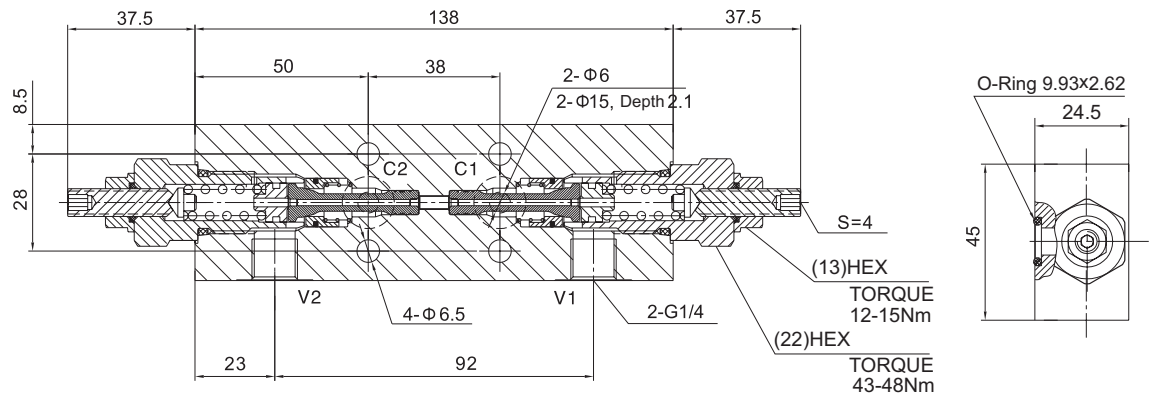

OPERATION

It provides static and dynamic control of load by regulating the flow IN and OUT of the actuator, through ports C1 and C2. This valve module includes 2 sections, each one composed by a check and a relief valve pilot assisted by pressure in the opposite line: the check section allows free flow into actuator, then locks the load against reverse movement; with pilot pressure applied at line across, the pressure setting of the relief is reduced in proportion to the stated ratio until opening and allowing controlled reverse flow. Back-pressure at V1 or V2 is additive to pressure settings in all functions.

SYMBOL

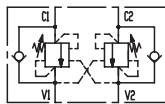

SPECIFICATIONS

Max. Operating Pressure	350bar
Flow	See PRESSURE DROP VS. FLOW graph.
Pilot Ratio	4.1:1
Internal Leakage	5 drops/min. at nominal pressure
Temperature	-40°F to +250°F (-40°C to +120°C)
Filtration	See page N-1
Fluids	Mineral-based fluids with viscosities of 7.4 to 420 cSt.
Housing Material	Steel & Ductile iron rated to 350bar

PRESSURE DROP VS. FLOW

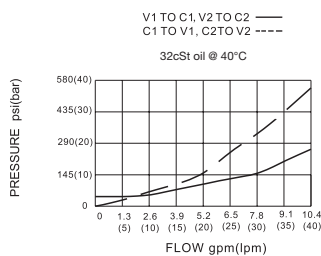

TO ORDER

DCB – MMB2 – RD78G – 2G – 35



1 Function DCB=Dual Counterbalance	5 Port Size 2G=G 1/4 *Other port sizes are available	6 Spring Range 35=1450-5000psi(100-350bar) Preset:3500psi(350bar) 175bar/Turn Factory pressure setting established at 5l/min.
2 Connection Type		
3 Size		
4 Pilot Ratio G=4.1:1		